

ZELOS TP-733VTS

Fully Automatic Vertical Pallet Strapping Machine (top-seal)

TP-733VTS is ideal for general palletized products. It is also suitable for those with low package height. The top sealing design provides the highest strapping efficiency onto the packages. The easy operating SIEMENS touch panel provides simple interface for operator to control and monitor the task. With quick connection to master control system, TP-733VTS can perfectly fit every end-of-line packaging operation.

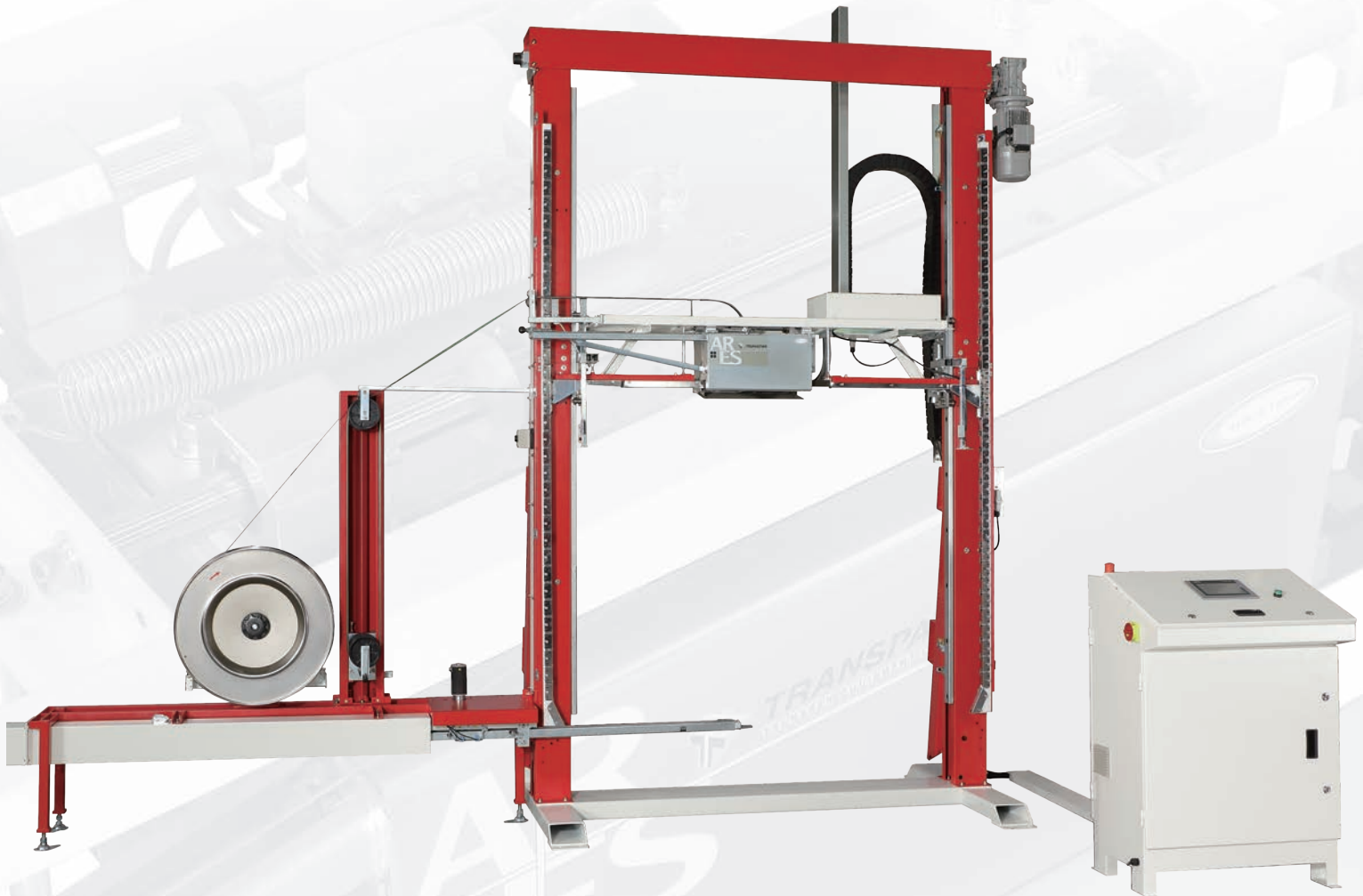

Main Features

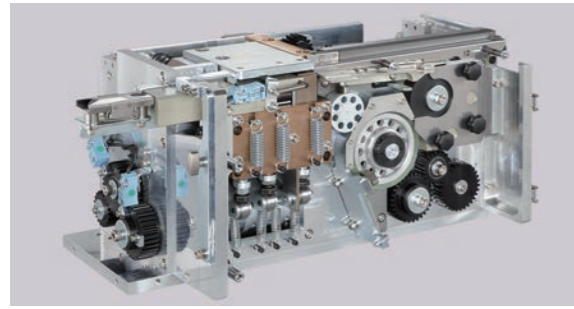

ARES TP-733-SH Strapping Head

Use the latest German-made DC brushless motor technology to provide the highest level of accuracy and reliability. Without belts and pulleys, its compact design greatly minimizes the numbers of moving parts and maintenance cost.



SIEMENS PLC and HMI

The SIEMENS PLC and HMI provide easy adjustments, operation instructions, troubleshooting guides, and real-time sensor status display.



Floating Head

The floating head can equalize the tension force around the package to optimize strap holding performance.

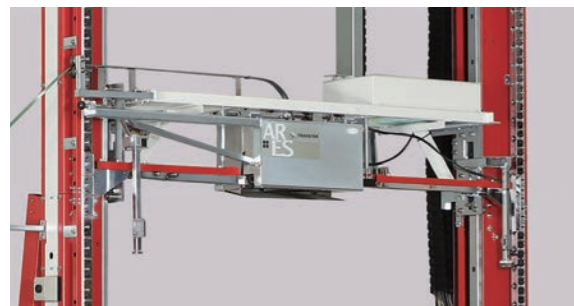

Strap can be fed at any height

The strapping head does not need to go back to home position for strap feeding. It greatly increases the efficiency and reduces preparation time for next strap cycle.

More Features

Friction Weld Sealing Technology

The advanced friction weld sealing technology guarantees reliable joint and high sealing efficiency for both PP and PET strapping. Tension force is up to 3200 N (320 kg). No fumes and odours. Ready to use once turned on.

Free Access to Strap Guides

Quick access to the strap guides without using any tools. The most maintenance friendly design.

All Electric Driven Design

No air consumption is required. The performance of the machine will not be restricted by the air supply.

Strap End Ejector

Eject end of strap automatically from the inlet of strap feeding. Easy to clean the end of strap and get the machine ready for next coil of strap.

Adjustable Speed for Strapping Head Movement

The ascent and decline speed of strapping head can be adjusted between 70 and 200 mm/sec to prevent damage on packages.

Excellent Package Top Detection

There are sensor and detection plate to make sure the strapping head stop precisely and softly at the time it touches the package.

Dual Channel E-stop

This provides an additional emergency stop circuit loop to ensure the E-stop operation if either loop is invalid, fulfilling a higher-level safety requirement.

Preprogram Setting for Multiple Strapping Tasks

It can store 10 strapping tasks. There is no need to adjust the setting when changing to different strapping task requirements. Reduce downtime and save cost.

Options

- Lower tension range (200-1200 N)
- Light tower with low strap sensor
- Air conditioner for electric control cabinet
- **Adding underfeed channel**
Suitable for mixed package types and sizes. Be able to switch between lance and underfeed channel automatically. (patent registered)
- Automatic self-adjusting strapping head height for next package
- End of strap signal
- Uplifted support
- Underfeed channel only (remove standard feature "movable lance")



*The conveyor is not part of TP-733VTS.

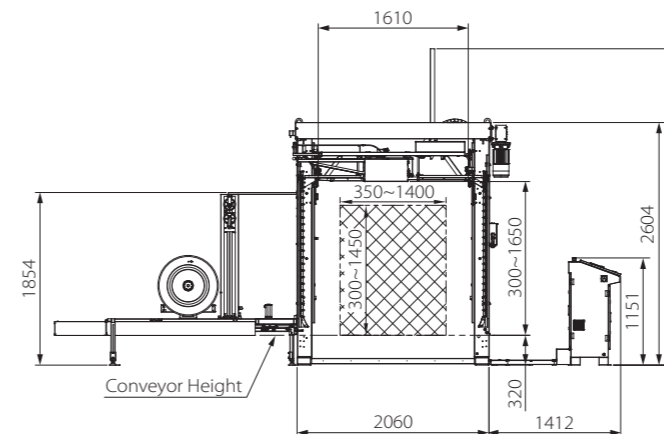
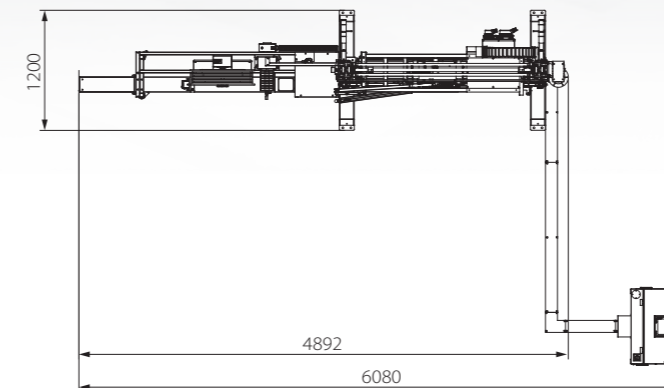

TP-733VTS

Arch Sizes

H \ W	1600	2000	2400
1650	Ⓢ		
2050			
2450			
2850			

Ⓢ Standard size: 1600 mm (W) x 1650 mm (H)

Technical Data

Capacity	Up to 63 pallets/hour (2 parallel straps)
Strap Type	PP and PET strapping
Strap Width	9 mm, 12 mm, 15.5 mm, or 19 mm
Tension Range	1,100 - 3,200 N (standard) 200 - 1,200 N (option)
Minimum Package Size	350 mm (W) x 300 mm (H)
Strap Core Size	406 mm
Electrical Requirements	220V, 380V, 400V, 415V 50/60Hz 3PH

**Offer the Maximum Value
with the Minimum Cost.**

Always More than You Expect.

